

SCHULTE®

FM-250 Belly Mount Power Delivery Frame
FM-230 Front Mount 3pt Hitch



Versatile, Quick Attach Mounting Systems for New and Existing 3pt Snowblowers

- 1** The FM-250 belly mount power delivery frame and FM-230 front mount 3 point hitch create an excellent addition to your Schulte RDX-110 snowblower, SDX-960 snowblower or any 96" or larger 3pt snow blowers or 3pt implement.
- 2** Designed to work on tractors in the 85 to 250 horsepower range with 1000 RPM drive systems.
- 3** The FM-250 power delivery frame's 47" adjustability makes mounting to most tractors easy.
- 4** The FM-230 front 3pt hitch has 10,000 lbs lift capacity at 24".

G O N U M B E R O N E . . . G O S C H U L T E !

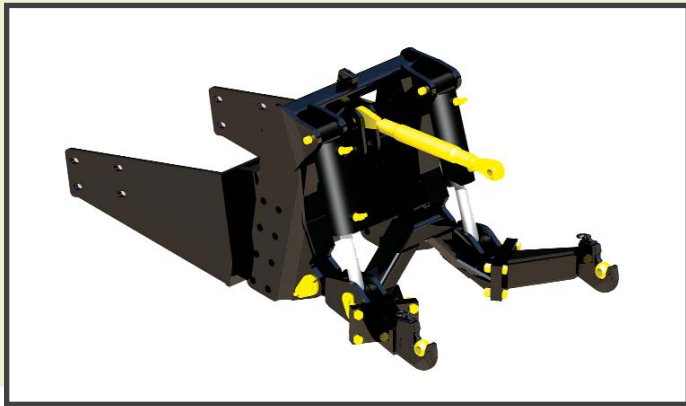
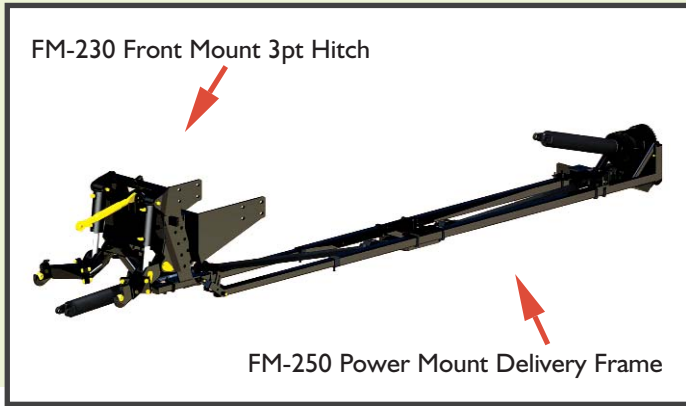

A perfect combination for Schulte's model SDX-960 and RDX-110 is the FM-250 Belly Mount Power Delivery Frame and the FM-230 Front 3pt hitch.

The design intent of this frame assembly and hitch is to create a hitch that will front mount any of our existing large snow blowers quickly and easily, and also give the operator the versatility of a front three point hitch when the snow blower is not in use.

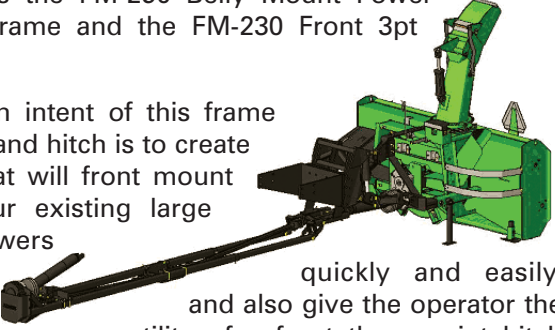

The FM-250 Belly Mount Power Delivery Frame was designed with adjustment in mind. Depending on tractor size, the FM-250 Belly Mount Power Delivery Frame has adjustability of 47" due to two size 8 BP drive shafts, a

mid mounted straight shaft, and telescoping 2.5" x 2.5" square tubes. The FM-250 Belly Mount Power Delivery Frame can transfer 250hp to the front of the tractor via a reversing gearbox which is a 1:1 ratio. A 1.84:1 gearbox is also available when mounting a 540 rpm implement. The front PTO is adjustable as well mounting underneath the main arm frame.

The FM-230 front mount 3pt hitch mounts to the front of your tractor. It has complete adjustability for different wheel sizes & implements. When choosing the FM-230 front mount 3pt hitch, please state the model number & year of your tractor. The 3 1/2" x 8" cylinders give a lift capacity of 10,000lbs at 24". The quick attach three point hooks are standard and feature ball bushings. The hooks are removable when not in use. The lower lift arms pivot on two 1 1/2" pins.

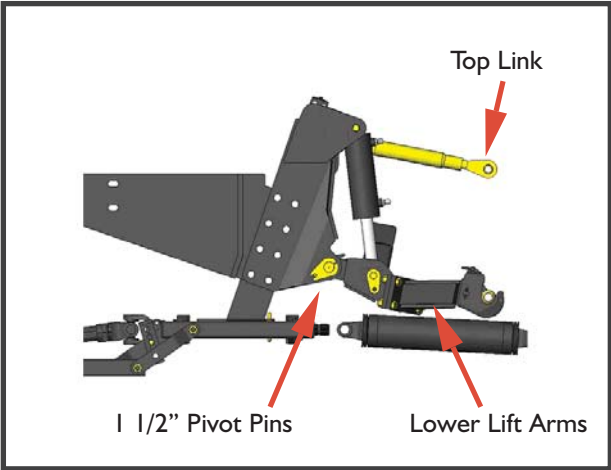

SPECIFICATIONS		
FM-250 Belly mount power delivery frame; FM-230 front mount 3pt hitch		
	FM-250	FM-230
Tractor Horsepower	250HP max	-
Lift Capacity @ 24"	-	10000lbs
Adjustment	47"	-
Lift Cylinder Size	-	3.5" x 8"
Shaft Sizes	1.75"	-
Bearings	1.75" NTN	-
Driveshaft	BP S8	-
OPTIONS		
Hydraulic banks for plow options	4	4
Gearbox	1.84:1, 1:1	-



Schulte Industries Ltd.,
 P.O. Box 70, Englefeld, Saskatchewan, Canada S0K 1N0
 Tel: (306) 287-3715 Fax: (306) 287-3355
 E-Mail: info@schulte.ca
 Visit our Web site at: www.schulte.ca
 Schulte is a registered trademark of Alamo Group Inc.

ISO 9001:2000



Sold By:

Schulte Industries Ltd. reserves the right to change the design, material and specifications of its products without notice. Illustrations may include optional equipment and accessories, and may not include all standard equipment. Part No. 1000-141